

Uniform Procedures For Collision Repair

CS01S—Radiator Core Support, Welded-On

© Copyright 1998 Inter-Industry Conference On Auto Collision Repair

v.2.3



1. Description

This procedure describes the repair and complete or partial replacement of a welded-on steel radiator core support. Inspection and evaluation requirements are also included.



2. Purpose

The purpose of this procedure is to provide industry-accepted requirements for performing high-quality repair of welded-on steel radiator core supports. This procedure is intended for use by professionals who are qualified through training and experience.



3. Referenced Documents

The following documents are considered part of this procedure by reference.

3.1 Procedures

- CP01S Corrosion Protection
- EM01 Emission Label
- HM01 Hazardous Materials
- ME01 Three-Dimensional Measuring
- PS01 Personnel Safety
- RF01S Surface Preparation
- RF41 Finish Application
- ST01S Stress-Relieving Heat Limitations
- ST11 Structural Straightening
- WE01S GMA (MIG) Plug Weld
- WE51S Squeeze-Type Resistance Spot Weld

3.2 Other Information

- Vehicle-specific dimension specifications
- Vehicle-specific repair information



4. Equipment And Material Requirements

4.1 Straightening And Measuring Equipment

Use straightening equipment as described in **ST11**.

Use measuring equipment as described in **ME01**.

4.2 Welding Equipment

Use **GMA (MIG) welding** equipment as described in **WE01S**.

Use **squeeze-type resistance spot welding (STRSW)** equipment as described in **WE51S**.

Note: Some vehicle makers recommend against the use of STRSW for replacing spot welds.



5. Damage Analysis

5.1 General Damage

Inspect a welded-on radiator core support and adjacent parts for these types of damage:

- visible damage
- corrosion**
- dimensional misalignment
- improper previous repairs
- damaged finish

5.2 Inspection Of Mounting Locations

Inspect for damage at mounting locations, such as these:

- airbag impact sensors
- energy absorbers
- air conditioning condenser
- radiator
- headlamps
- hood latch
- engine mounts
- suspension mounting locations

Determine how much of the core support can be straightened and the portion that must be replaced. Verify the availability of replacement parts.



6. Personnel Safety

6.1 General Safety

General safety information is in **PS01**.

6.2 Pulling Safety

Pulling safety information is in **ST11**.

6.3 Welding Safety

Welding safety information is in **WE01S** or **WE51S**.



7. Environmental Safety

7.1 Hazardous Materials

Hazardous material safety information is in **HM01**.



8. Vehicle Protection

8.1 Stress-Relieving

If heat is used for **stress-relieving**, use temperature-measuring methods as described in **ST01S**.

Note: Some vehicle makers recommend against the use of heat for stress-relieving.

8.2 Electronic Parts

To protect computers and other sensitive parts from damage:

- Follow the vehicle maker's recommendations for recording and resetting **electronic memories**.
- Ensure that the ignition switch is in the LOCK position, and the key is removed.
- Disconnect and isolate the negative battery cable, and disarm the **passive restraint system**. Follow the vehicle maker's recommendations.
- Carefully remove computer modules when welding or heating within 300 mm (12") or a greater distance when recommended by the vehicle maker.



(cont'd)



8. Vehicle Protection (cont'd)

- ❑ Protect modules, connectors, and wiring from dirt, heat, static electricity, and moisture.
- ❑ Loosen or remove any wiring harnesses or electrical parts that could be damaged during the repair process.

Remove the battery if it is near an area to be welded or heated.

8.3 Adjacent Areas

Protect glass, upholstery, and other cosmetic surfaces from welding, grinding, or cutting sparks. Remove interior trim that cannot be protected.



9. Repair Procedure

9.1 Straightening

To straighten a welded-on radiator core support:

- ❑ 1. Make sure the vehicle is properly anchored to the straightening system.
- ❑ 2. Make measurements to determine the location of the radiator core support.
- ❑ 3. Make underhood measurements to determine the locations of the airbag sensor mounting locations, if specified by the vehicle maker.
- ❑ 4. Use **multiple pulls** and stress-relieving to return the radiator core support and the surrounding structure to proper dimensions. Follow the **tolerance** recommendations of the vehicle maker. If no recommendations are given, use a tolerance of ± 3 mm ($\frac{1}{8}$ "). Use a **three-dimensional measuring system** and adjacent panels to verify that the part is properly aligned.
- ❑ 5. If heat is used for relieving stress, follow the vehicle maker's temperature and time recommendations. If the part cannot be identified as **mild steel**, treat it like **high-strength steel (HSS)**.
Note: Some vehicle makers recommend against the use of heat for stress-relieving.
- ❑ 6. Plan to replace any areas that are **kinked**, have stress cracks, or develop cracks during straightening. If complete core support replacement is required, see **9.2** and **9.3**. For partial replacement, see **9.4** and **9.5**.
- ❑ 7. Apply corrosion-resistant **primer** to all interior and exterior surfaces damaged by the collision, repairs, or anchoring.

(cont'd)



9. Repair Procedure (cont'd)

- 8. Apply **seam sealers** as necessary to seal the joints and restore the appearance. Reprime if required by the product maker.
- 9. Apply anti-corrosion compounds to all enclosed areas.
- 10. Refinish areas damaged by the collision, repairs, or anchoring, as required to restore the appearance. Refinish cosmetic surfaces after all body repairs are complete.
- 11. Continue vehicle reassembly.

9.2 Complete Removal

To remove a complete welded radiator core support:

- 1. Perform underhood and underbody measurements and adjacent panel alignment and straightening. See **9.1**.
- 2. Identify and mark all spot weld locations.
- 3. Remove the spot welds. Do not damage the parts attached to the radiator core support which are not to be replaced.
- 4. Remove the damaged radiator core support. Do not discard any labels until replacements are obtained.
- 5. Remove any burrs or spot weld **nuggets** from the mating **flanges**, and repair any damage. Avoid removing any **zinc coating**.
- 6. Straighten the mating panel edges, if necessary to ensure a proper fit-up with the replacement core support.

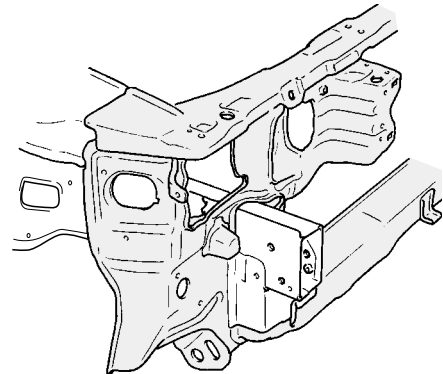

9.3 Complete Installation

To install a complete replacement welded-on radiator core support:

- 1. Perform a trial fit of the replacement parts.
- 2. Clean the mating surfaces. Avoid removing any zinc coating.
- 3. Refer to the vehicle maker's **body repair manual** for the recommended welding method. STRSW should be used only when recommended by the vehicle maker.
- 4. Refer to the vehicle maker's recommendation for the location, number, and size of **plug weld** holes. If no recommendations are available, punch or drill 8 mm ($\frac{5}{16}$ ") holes in the outer panel at the same locations used originally by the vehicle maker. If STRSW is used, refer to the vehicle maker's recommendations for the electrode diameter, weld locations and spacing, etc.
- 5. Test-fit the replacement core support and clamp it in place.
- 6. Remove the replacement core support from the vehicle.

(cont'd)



9. Repair Procedure (cont'd)

- 7. Apply **weld-through primer** to all weld mating surfaces that do not have zinc coating, or where the zinc coating was removed. Follow the vehicle maker's recommendations. Due to the poor adhesion property of some weld-through primers, it may have to be removed from all exposed surfaces after welding, before applying other coatings and sealants.
- 8. Apply **weld-bond adhesive** when recommended by the vehicle maker.
- 9. Position the part on the vehicle and clamp it in place.
- 10. Use a measuring system and adjacent panels to verify that the part is properly aligned.
- 11. **Tack weld**, or securely clamp, the core support in position.
- 12. Recheck the alignment using the measuring system and the adjacent panels.
- 13. Make test welds, before welding on the vehicle, using the same type and thickness metal that will be welded on the vehicle. Make the test welds in the same position as the welds on the vehicle, using weld-through primer if applicable. Visually inspect and **destructively test** the welds before welding on the vehicle.
- 14. Make the required welds.
- 15. Use the three-dimensional measuring system and adjacent parts to verify that the core support is still properly aligned.
- 16. **Dress the welds**, if necessary.
- 17. Apply corrosion-resistant primer to all interior and exterior surfaces damaged by the collision, repairs, or anchoring.
- 18. Apply seam sealers as necessary to seal the joints and restore the appearance. Reprime if required by the product maker.
- 19. Apply **anti-corrosion compounds** to all enclosed areas.
- 20. Refinish areas damaged by the collision, repairs, or anchoring, as required to restore the appearance. Refinish cosmetic surfaces after all body repairs are complete.
- 21. Install any labels previously removed.
- 22. Continue vehicle reassembly.



9.4 Partial Removal

To remove the damaged portion of the welded-on radiator core support assembly for partial replacement:

- 1. Perform underhood and underbody measurements and adjacent panel alignment and straightening. See **9.1**.

(cont'd)



9. Repair Procedure (cont'd)

- 2. Identify and mark the spot weld locations on the portion to be removed.
- 3. Remove the spot welds. Do not damage the parts that are attached to the radiator core support if they are not to be replaced.
- 4. Remove the portion of the core support from the vehicle. Do not discard any labels until replacements are obtained.
- 5. Remove any burrs or spot weld nuggets from the mating surfaces, and repair all damage. Avoid removing any zinc coating.

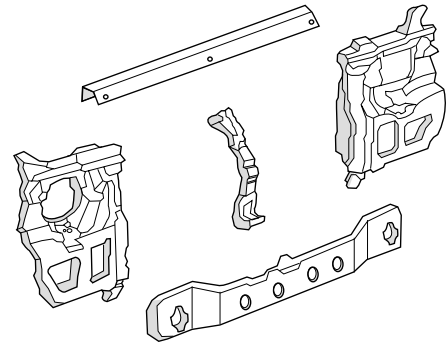

9.5 Partial Installation

To install a portion of the welded-on radiator core support assembly:

- 1. Perform a trial fit of the replacement parts.
- 2. Clean the mating surfaces. Avoid removing any zinc coating.
- 3. Refer to the vehicle maker's body repair manual for the recommended welding method. STRSW should be used only when recommended by the vehicle maker.
- 4. Refer to the vehicle maker's recommendations for the location, number, and size of plug weld holes. If no recommendations are available, punch or drill 8 mm ($\frac{5}{16}$ ") holes in the outer panel at the same locations originally used by the vehicle maker.
- 5. Test-fit the partial core support and clamp it in place.
- 6. Remove the partial core support from the vehicle.
- 7. Apply weld-through primer to all weld mating surfaces that do not have zinc coating, or where the zinc coating was removed. Follow the vehicle maker's recommendations. Due to the poor adhesion property of some weld-through primers, it may have to be removed from all exposed surfaces after welding, before applying other coatings and sealants.
- 8. Apply weld-bond adhesive when recommended by the vehicle maker.
- 9. Position the partial core support on the vehicle and clamp it in place.
- 10. Use a three-dimensional measuring system and adjacent panels to verify that the partial core support is properly aligned.
- 11. Tack weld, or securely hold, the partial core support in position.
- 12. Recheck the alignment using the measuring system and the adjacent panels.

(cont'd)



9. Repair Procedure (cont'd)

- 13. Make test welds, before welding on the vehicle, using the same type and thickness metal that will be welded on the vehicle. Make the test welds in the same position as the welds on the vehicle, using weld-through primer if applicable. Visually inspect and destructively test the welds before welding on the vehicle.
- 14. Make the required welds.
- 15. Use the three-dimensional measuring system and adjacent panels to verify that the core support is still properly aligned.
- 16. Dress the welds, if necessary.
- 17. Apply corrosion-resistant primer to all interior and exterior surfaces damaged by the collision, repairs, or anchoring.
- 18. Apply seam sealers as necessary to seal the joints and restore the appearance. Reprime if required by the product maker.
- 19. Apply anti-corrosion compounds to all enclosed areas.
- 20. Refinish areas damaged by the collision, repairs, or anchoring, as required to restore the appearance. Refinish cosmetic surfaces after all body repairs are complete.
- 21. Install any labels previously removed.
- 22. Continue vehicle reassembly.



10. Use Of Recycled (Salvage) Parts

10.1 Condition Of **Salvage Parts**

Do not install a salvage core support having any of these defects:

- unrepairable damage
- corrosion that has caused pitting
- improper previous repairs
- missing mounting locations

10.2 Preparation Of Salvage Parts

To prepare a salvage core support for installation:

- Clean the part to a remove dirt, wax grease, undercoating, corrosion, etc.
- Trim the parts to fit.
- Remove all **heat-affected zones**.
- Make sure the parts are not deformed along the weld joints, to ensure proper fit-up.



11. Inspection And Testing

11.1 Inspection Of A Repaired Or Replaced Welded-On Core Support

Inspect a repaired or replaced welded-on core support for these conditions:

- dimensional alignment
- proper alignment to adjacent panels
- weld quality
- proper application of corrosion protection
- proper finish appearance and film thickness
- proper installation of all labels

Correct any defects.