

Waterborne Materials— Solution To A Tough Problem

Waterborne materials are one of the solutions paint manufacturers have come up with in response to environmental concerns. For the paint industry, those concerns center on the effects of volatile organic compounds (VOCs). These compounds, found in most paint solvents, evaporate when sprayed, creating a pollution hazard. The challenge to paint manufacturers has been to develop materials that contain less solvents, yet keep the same appearance, ease of use and handling that users have come to know. In waterborne materials, high percentages of VOC solvents are replaced with water.

U.S. laws which went into effect in January, 1992 focused mainly on undercoats. So, the waterborne materials now available for collision shops are surface cleaners, primer surfacers, primer sealers and primer fillers. These materials were developed to avoid harming the environment but still perform well. In fact, these materials even hold certain advantages over traditional solvent-borne materials. These advantages will be pointed out later in this article.

Continued—Page 7

Running On Alternate Fuels



Ford has converted a fleet of Econoline vans and Tauruses to flexible-fuel vehicles that use methanol, gasoline, or any combination, from the same tank. (Photo courtesy of Ford Motor Company)

It isn't too early to talk about vehicles that run on fuels other than gasoline and how they will affect collision repair. The California Air Resources Board requires the sale of 150,000 alternate-fuel (or low emissions) vehicles by 1996. At least 300,000 alternate-fuel vehicles are expected by 1998. In the near term, most vehicles will be able to run on gasoline as well as the alternate fuel. These vehicles are usually called "flexible-fuel" vehicles. As alternate fuels become more commonly available, manufacturers will build vehicles that run on those fuels alone.

Ford will have a fleet of 2,500 flexible-fuel Tauruses in California this year. Last November, GM announced the availability of 4,000 flexible-fuel Lumina's for sale to the public. There are a number of fleets running on propane. There are also

some public utility fleet vehicles using natural gas.

Presently available alternate fuels fall into two groups:

- **alcohol fuels**, like methanol and ethanol
- **gaseous fuels**, like compressed natural gas and liquefied petroleum gas

There is a third and separate group—electricity. A future article will discuss advances being made in electrically powered vehicles.

ALCOHOL FUELS

Methanol and ethanol fuels can be handled in much the same way as gasoline. They are both liquid fuels. Most engines designed to run on alcohol fuels can also run on

Continued—Page 2



Figure 1—Most engines designed to run on methanol, such as this Saab prototype, can also run on gasoline or any combination of the two. (Photo courtesy of Saab Cars USA, Inc.)

gasoline or any combination of the two (see Figure 1). That is why they are called flexible-fuel, or multi-fuel, vehicles. In fact, a little bit of gasoline is generally mixed with alcohol fuels. **M85** is the name for a mixture of 85 percent methanol and 15 percent gasoline.

Blending a small amount of gasoline with the alcohol is done for several reasons. Gasoline vaporizes at lower temperatures and provides better cold engine starting. Alcohol burns with an invisible flame, but with the added gasoline, the flame is yellow. If there's a fire, it is easier to see.

Health Concerns

Like all other motor fuels, methanol and ethanol are highly toxic. Methanol can cause blindness if you drink it. If any liquid fuel gets on your skin, wash it off immediately. There are special gloves made of nitrile rubber that are resistant to motor fuel, and should be worn if there is a chance of getting fuel on your hands.

Fuel System Service

Alcohol-based fuels should be treated just like gasoline. For example, if you must remove the fuel tank, you should empty it first. However, alcohol fuels should be drained into a separate holding tank. If any alcohol fuel gets into a tank used for storing gasoline, it will contaminate the gasoline. On some vehicles, there is a screen in the filler neck to discourage siphoning, especially by fuel thieves who often use their mouths and a piece of rubber hose.

Fuel lines are serviced the same way as those on gasoline-powered vehicles. Methanol is much more corrosive than gasoline and will harm regular hoses, steel lines and fuel tanks. Make sure to use tubing and hoses designed for methanol fuels. The same goes for gaskets, seals and O-rings. Even gas caps may not be interchangeable. Ethanol is also corrosive, but not as much as methanol.

Vaporization And Explosion Dangers

Alcohol boils at a relatively low temperature, about 140°F (60°C). However, it doesn't vaporize like

gasoline at lower temperatures. Gasoline helps get a cold engine going because it easily vaporizes in a cold intake manifold. Alcohol vaporizes at 0°F (-18°C). Danger exists if the vapors collect in a trench or pit where they can be ignited by a spark or flame. Make sure there is plenty of ventilation when grinding, cutting or welding. There's no problem in paint booth operations with these fuels.

Paint Problems

Both methanol and ethanol behave like solvents. They can dissolve a lacquer finish down to the primer. They can even blister body filler. Urethane enamels are more resistant once they have had time to cure. This is usually a week or two. If alcohol fuels get on the finish before hardening, they can soften and discolor it.

COMPRESSED AND LIQUEFIED GASES

There are two kinds of bottled gas now used in vehicles. They are Compressed Natural Gas (CNG), and Liquefied Petroleum Gas



TECHNICAL INFORMATION FOR THE COLLISION INDUSTRY

Editorial Offices: I-CAR Tech Centre, 4 Systems Drive, Suite C, Appleton, WI 54914. 1.800.TECH.990, Fax 920.749.0336.

The I-CAR *Advantage*, published six times per year, features technical articles for the Collision Industry.

Articles submitted for publication may not be used and will not be returned.

For subscription information, contact:

USA 1.800.ICAR.USA
Canada 1.800.565.ICAR
New Zealand 0800.999.933

For permission to reproduce any of the contents in this publication, contact the I-CAR Tech Centre at:

1.800.TECH.990 or 920.749.0444

or e-mail:
advantage@i-car.com

Visit the I-CAR web site at:
<http://www.i-car.com>

(LPG). These two fuels are usually handled about the same in the collision repair shop. These gases are stored in containers like those used with oxygen and acetylene.

Neither CNG nor LPG is very dangerous, but if there is a leak, and the right mix of gas and air is present, a spark could cause an explosion. If you're going to be welding, grinding, or cutting on the vehicle, turn off the gas supply at the tank, and run the engine to purge the fuel lines. Then disconnect the battery.

If you didn't purge the lines and you discover a leak, immediately open the doors and windows. Stop all cutting, grinding or welding. Once you fix the leak, make sure the shop is free of gas before going back to your work.

LPG or CNG tanks are designed to withstand pressures well above their fill ratings. When they come into your shop, the tanks are usually not full. LPG tanks cannot be filled beyond 80 percent, or the relief valve will open (see Figure 2). The relief valve also opens when the internal tank pressure reaches 312 psi. That occurs at 150°F (65.5°C). The tank vapor pressures that develop at heating temperatures in a spray booth are well below the rated burst pressures of the tanks, but may exceed the rated relief valve pres-

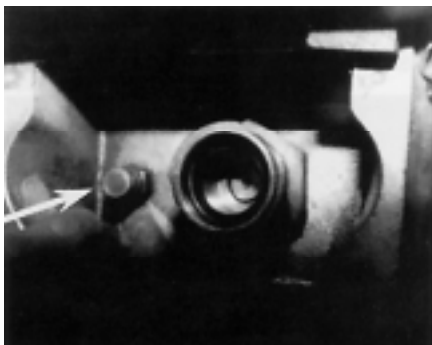

Figure 2—The service valve for refueling the LPG tank features a relief valve. Propane will release from the valve when the tank reaches maximum 80% full or the vapor pressure reaches 312 psi.

Vapor Pressures Of LPG

Temperature		Approx. PSI
F°	C°	
-40	-40	3.6
-30	-34.4	8.0
-20	-28.9	13.5
-10	-23.3	20.0
0	-17.8	28.0
10	-12.2	37.0
20	-6.7	47.0
30	-1.1	58.0
40	4.4	72.0
50	10	86.0
60	15.6	102.0
70	21.1	127.0
80	26.7	140.0
90	32.2	165.0
100	37.7	196.0
110	43.3	220.0
150	65.5	312.0

Figure 3—LPG tank pressures that develop at booth temperatures could reach the level to cause the relief valve to open. These pressures, however, are well below the 1300 psi burst pressure.

sures (see Figure 3). Booth manufacturers and local codes require that **all LPG and CNG tanks must be removed before the vehicle enters the spray booth.**

Compressed Natural Gas (CNG)

Compressed Natural Gas is a form of methane, a gas found in nature. It is usually collected as a byproduct from oil wells. Methane can also be produced from garbage or coal. When you pass a garbage dump at night, you see pale blue flames on pipes used to vent the methane from the decomposing garbage. Although the flames also burn during the day, they are almost invisible. Some larger dumps are now collecting the methane and selling it for commercial use.

Methane is lighter than air. It rises when it escapes and poses a slight shop danger, compared to other alternate fuels, if there is a leak. Space heaters in shops are usually suspended from the ceiling, high above any gasoline vapors that may escape. However, if enough methane escapes and floats up, it may be ignited by the heater or its pilot light. If you have to ventilate the shop in an emergency, simply opening the door may not get out all the trapped methane. If your shop has ceiling vents, open them.

Liquefied Petroleum Gas (LPG)

Liquefied Petroleum Gas is generated during the process of refining crude oil. LPG is made up of mostly propane, but sometimes contains a small amount of butane. Today, there are more vehicles powered by propane than any other type of alternate fuel. A typical system installed on a passenger car is shown in Figure 4. Over 350,000 vehicles are using propane in the United States and 3.5 million worldwide. There are over 10,000 places to buy propane in the U.S.

Propane is heavier than air. It sinks to the floor and collects in trenches and pits, similar to gasoline fumes. Any fumes caused by a leak can be usually cleared quickly by opening doors and windows.

Fuel Tanks And Lines

The tanks, or bottles, that hold CNG or LPG are not like the tanks that hold gasoline or alcohol fuels. They are much thicker and heavier. The brackets used to support them are also quite sturdy. In cars, the tanks are normally stored in the trunk, for

Continued—Page 4

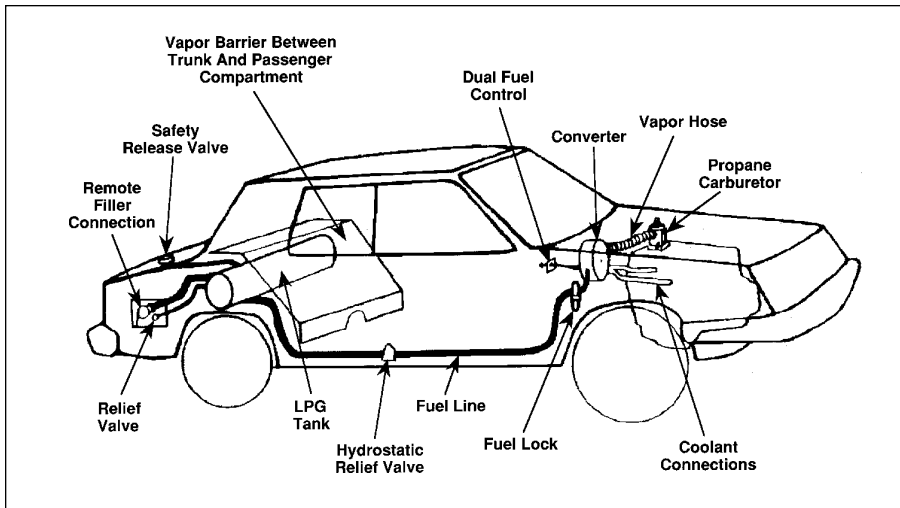

Figure 4—A typical LPG fuel system installed in a passenger car. Today, there are more vehicles powered by propane than any other type of alternate fuel. (Courtesy of National Propane Gas Association)

easy access (see Figure 5). CNG tanks and LPG tanks are NOT interchangeable. CNG is stored at up to 3,000 psi. The tanks may be the familiar steel type that look like oxygen and acetylene tanks. They may also be made of aluminum with a hard fiberglass covering on the outside. LPG is stored at 160 psi. The tanks are rated at 1,300 psi. That's four times the pressure they will normally reach.

Both gases are stored at pressures too high for the engine to handle, so regulators are used to reduce the pressure before the gas enters the mixer. The mixer blends the gas with air. It takes the place of the carburetor. On CNG vehicles, pressure is regulated in a two-stage process. Some vehicles have two separate regulators while others

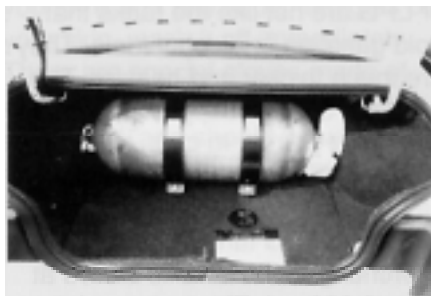

Figure 5—Most cars powered by CNG or LPG have the fuel tanks in the trunk.

have a single, two-stage regulator. Replacement lines, as well as fittings, seals and other parts, must be compatible with CNG or LPG. The pipes and connectors used to carry natural gas in homes are NOT satisfactory for automotive use. Be sure all replacement parts meet or exceed original equipment specs.

Because of the pressures involved, CNG fuel lines must be very strong so they won't burst. They are 3,000 psi, stainless steel. No rubber or flexible lines are used. To allow for tubing expansion and to absorb vibration, the lines are looped in one or two places. This is not extra tubing that you can shorten, and DON'T straighten it out.

LPG fuel lines carry lower pressures than CNG lines. Most LPG fuel lines are flexible, and rated at 350 psi with a 1,750 psi burst pressure. The lines must be specially designed for use with LPG. They are not the same kinds of lines used for hydraulic fluids. The rubber used for LPG fuel line is less porous to keep the gas from leaking out. The flares for the fittings are a slightly different angle, too. Hydraulic lines have a 37° flare. LPG lines have a 45° flare.

If you must replace an LPG or CNG fuel line, turn off the fuel valve near the tank first. Although all tanks have fuel cutoff devices that prevent fuel flow if a line ruptures, don't rely on it alone. Besides, once it pops, the safety valve has to be replaced. CNG fuel line is usually a single, continuous stainless steel tube. LPG fuel line may be in several sections.

The lines usually run under the vehicle like other fuel lines and brake lines. Be careful not to cut or crimp them when straightening a vehicle. Be extra careful not to attach your clamps on any lines. If you must work close to a fuel line, shut off the fuel. The shutoff valve is usually located on the tank. On CNG vehicles, there is also an emergency shut-off valve that takes only 1/4 turn to close. A red label should show its location (see Figure 6). To use up any fuel still in the lines, start the engine and allow it to run until it dies. Then disconnect the battery.



Figure 6—Compressed natural gas (CNG) tanks have a shut-off valve that must be identified with a red label. Here, the valve is inside the vapor-proof pouch.

In the U.S., laws require labels on the rear of CNG and LPG vehicles. It is usually on the deck lid. If you repair or replace the deck lid, install a new label before returning the car into service. You can get labels wherever CNG or LPG are sold. The CNG label is white with a diamond shape and the letters CNG in blue in the center. The



Figure 7—Vehicles fueled by LPG or CNG must be clearly marked. You must replace any decals removed during service.

LPG sticker is usually black with the word PROPANE in white or silver in the center of the diamond (see Figure 7).

Under The Hood

The regulators and mixers for LPG and CNG are usually located in the engine compartment. The mixer on throttle body injected engines is on the throttle body. On carbureted engines, the mixer is on the carburetor (see Figures 8 & 9).

When vehicles are modified to run on gaseous fuels, parts are often relocated to make room for the regulator. Often the battery is moved, sometimes all the way to the trunk. Other parts that are commonly moved are the windshield washer bottle and the coolant overflow bottle. Keep this in mind if you have to reconstruct the front of the vehicle.

Continued—Page 6



Figure 8—The propane mixer sits on top of the throttle body on this Ford 3.8 liter engine.

Alternate Fuels At A Glance

Anything other than gasoline and diesel fuel is considered an alternate fuel. Here is a quick look at them.

REFORMULATED GASOLINE—It would be stretching the term to call reformulated gasoline an alternate fuel. Actually, it is gasoline with some of the more volatile compounds removed. This reduces the hydrocarbons that enter into the atmosphere and make smog. Alcohol-based additives are used instead. Reformulated gasoline is sold in some major cities today. Neither the motorist nor the vehicle can tell that reformulated gasoline is being used.

METHANOL—a liquid alcohol that can be produced from natural gas, coal, wood or biomass (garbage). It is less volatile than gasoline. This makes cold engine starting more difficult. Usually, 15 percent gasoline is blended with 85 percent methanol to improve starting. This mixture is called M85. A gallon of methanol has 40 percent less energy than a gallon of gasoline. Vehicles using methanol will get 40 percent less fuel economy so they must be refueled more often.

ETHANOL—This is a liquid grain alcohol that can be made from corn, sugar or grains. Up to 10 percent

has been used for years to boost the octane of gasoline. At one time this was called Gasohol. Ethanol has one-third less energy than gasoline. Because of ethanol's lower volatility, cold starts are more difficult.

LIQUEFIED PETROLEUM GAS (LPG)—LPG is used in some fleet vehicles and forklifts. It is commonly used for barbecue grills and rural heating. It puts out very few hydrocarbons from the exhaust and doesn't contribute to ozone pollution. It takes 1.3 gallons (4.9 liters) of LPG to equal the energy content of one gallon (3.8 liters) of gasoline, so fuel economy suffers.

COMPRESSED NATURAL GAS (CNG)—Natural gas, known as methane, is the traditional home heating and cooking fuel. It burns clean and costs about half that of gasoline. On the down side, the tanks must be four times the size of a gasoline tank and can weigh up to 500 pounds (227 kilograms). Home refueling compressors are expensive and they take several hours to refuel a vehicle. Commercial compressors, however, can refuel a vehicle in about one-and-one-half minutes. Driving range is a lot less compared to gasoline.



Figure 9—The CNG mixer on this V8 Chevrolet Caprice fits inside the air cleaner housing.

Paint Problems

Generally, there are no paint problems with LPG or CNG. Refueling is done with snap couplers like those on shop air hoses. Since CNG and LPG are both vapors, they don't spend more than an instant in contact with the finish. Most current LPG or CNG vehicles can also run on gasoline, so the filler pipe area is still in its normal location. The snap coupler fitting is usually in the trunk, under the hood, or sticking out of the grille.

IN REVIEW

In general, dealing with alternate fuel vehicles in the collision shop is not much different from dealing with those fueled by gasoline. Methanol, ethanol and gasoline should be stored separately. There are really no differences in how you do body work or painting. Selecting the right paint is important. Polyurethane enamel is the most resistant to alcohol fuels.

When servicing vehicles powered by LPG or CNG, turn off the gas supply at the tank, and run the engine to purge the fuel lines before welding, cutting, straightening, etc. The usual procedure of disconnecting the battery should be done only after you're sure any gas accumulation has been eliminated by venting. Remove LPG and CNG tanks before taking the vehicle into a spray booth.

If CNG leaks, it will rise rather than sink. This is the only fuel that is lighter than air so venting it must be done near the ceiling. Just use common sense. Think about what you are doing and you won't have any trouble servicing alternate fueled vehicles. **A**

Contaminated Fuel Tank

Fuel tanks often get contaminated during a collision, or if there's a delay in repairing a vehicle. If the vehicle is kept in storage during high changes in temperature, the fuel tank may build up condensation, possibly leading to corrosion. If the vehicle is not kept in a secured location, vandals may pour sand, dirt, gravel, sugar, etc. down the filler pipe.

If you suspect damage to the fuel tank, check for:

- obvious dents, punctures, cracks or holes in the fuel tank.
- signs of rust.
- puddles of fuel on the floor or ground.
- the smell of gasoline or diesel fuel around the fuel tank.

If fuel can escape from the fuel tank, then moisture can get in and quickly cause corrosion. Moisture and corrosion are the two greatest causes of contamination. Look for signs of fuel leakage. If you smell unburned fuel, that can be a sure sign of a problem. Disconnect the fuel supply line that goes to the engine. Crank the engine, and pump at least one pint (0.4 liters) of fuel into a clean container (glass is best).

Allow the container of fuel to sit undisturbed for 10–15 minutes to

allow any sediment to settle to the bottom. Particles or grains will be easy to find. Fluid contamination requires closer inspection. When contamination is discovered, remove the fuel tank from the vehicle. Drain any fuel into a separate container. Do not mix with any other hazardous waste and do not try to dispose of it yourself. Turn it over to your hazardous waste handler for proper disposal. Doing it yourself can not only be dangerous, but illegal.

Send the fuel tank to a radiator shop for complete cleaning. There, it will be "boiled" and flushed to remove any contaminants. Next, remove the fuel supply and return lines and clean them with pressurized air. Work from the engine side. Replace the lines if necessary.

If the vehicle features a fuel injection system, use a fuel injector cleaning system to remove any contaminants in the injection system. If the injector filters are clogged beyond the point of proper cleaning, replace with new injectors. Use a bore scope to check for scoring of the cylinder walls. Finally, inspect the filter on the fuel level float assembly inside the fuel tank. If clogged, replace with a new one.

THE CHALLENGE

Solvents allow the pigments and resins in paint to be sprayed on the vehicle and “set up” effectively. Faced with having to lower VOC solvent content, manufacturers had only two choices:

- reduce the amount of VOC solvents used
- change the type of solvent used

Most solvent-borne materials designed to meet VOC regulations will generally be high-solids. Tests show that high-solids materials work in some applications, but not all. Solvent-borne materials that are low in solvents are difficult to atomize and hard to apply. Spray guns can clog up with the thick material. It may be difficult to control the amount of material put on the panel surface. So chemists are turning to waterbornes as a way of producing low VOC materials. This is not to say that creating successful waterborne materials is easy. There are many challenges in making them workable in everyday shop use.

Using waterborne materials on vehicles isn't new. Vehicle manufacturers have been applying waterborne materials since the early 1980s in order to reduce VOC emissions. Also, waterborne materials provide control over the settling of metallic flake and result in lower film builds.

Factories are an ideal setting for proving the new technology, because temperature and humidity can be controlled. Finishes can be baked at extremely high temperatures. Large production facilities make it cost effective to invest in the kinds of equipment and production processes to provide this type of control.

However, none of these advantages are available to the typical collision shop. Shops can only control the environment to a certain degree, and need a product that is easy to use. This explains why OEMs have been using waterborne materials for some time, and the aftermarket only the last few years. But the fact that the paint manufacturers brought a workable waterborne technology to the aftermarket, is an industry success story.

GETTING TO KNOW WATERBORNE MATERIALS

There are features of waterborne materials that you should be aware of (see Figure 1). Knowing how to handle these materials will help make their application successful. Here are a few areas where waterborne materials differ from solvent-borne materials.

1. Drying Time

Waterborne materials look wetter longer, because water doesn't evaporate as quickly as solvent. Most solvent-borne materials use a

combination of several different solvents: fast drying, medium drying, and slow drying. All these play a role in how quickly the material goes on and covers the surface. Also, there are no temperature-rated reducers (accelerators, etc.) that can be used with waterborne material to speed up or slow down the drying time. Because of this, when using waterborne materials, you must work on controlling the drying time.

2. Application Environment

Controlling the environment is the single biggest factor when applying waterborne materials. Unlike vehicle manufacturers, the average shop owner can't invest in hundreds of thousands of dollars of equipment. Still, there are some important things the owner can do.

First, control cool or humid conditions, which slow the drying time of waterborne materials tremendously. Most paint manufacturers suggest that their products not be used in temperatures that fall below 55°F (13°C). Forced drying is important because water doesn't evaporate like solvents. The vehicle surface and the paint material should always be at the suggested temperature before the application begins.

The air flow around the spraying area is also important. Good air flow provides speedy evaporation of water from paint film. You have to be careful not to allow too much air movement, such as drying material with a spray gun, which may cause cracking (see Figure 2).

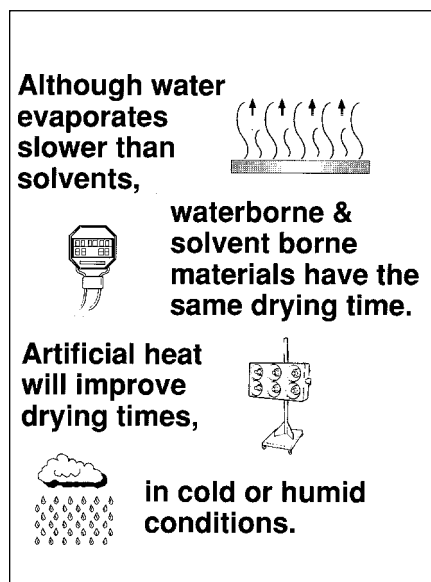

Figure 1—Waterborne materials have some different features you should be aware of.

Continued—Page 8

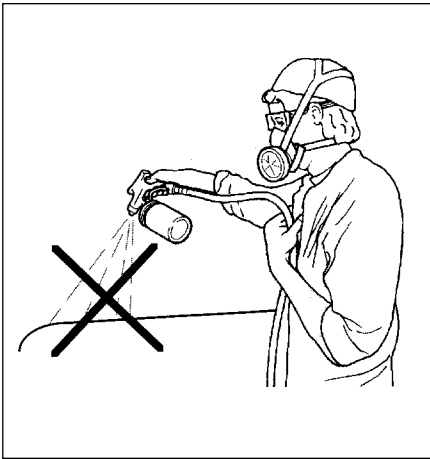

Figure 2—Don't dry waterborne materials with a spray gun. This allows too much air movement, and can cause cracking.

3. Corrosion Protection

Waterborne materials can provide excellent corrosion protection under a wide variety of applications. However, corrosion protection can fail if the material is not applied correctly.

There is no question that the water in these materials can be a source of corrosion, especially if the first coat is not allowed to dry before the next coat is applied. When this occurs, water can get trapped in the paint film, causing a potential corrosion problem. You must be patient when applying each waterborne coat. There is no "flash off" (surface looking dry while the material is wet underneath) with waterborne materials as there is with solvent-borne, so the material will look wet much longer.

Certain manufacturer's primer surfacers should only be applied after a pretreatment or precoat. If these types of primer surfacers are applied to bare metal without pretreatment, there will be a corrosion problem. Once again, these types of problems can be avoided simply by following the label instructions.

4. Waste Disposal

Solvent disposal services are choosing to handle the waterborne waste issue in different ways. Some will haul it away by itself for a price. Others will allow up to ten percent of waterborne waste to be mixed in with their solvent-borne waste. However, as waterborne materials become more common, the storage and/or destruction of their waste will become more of an issue. In fact, it may become the industry environmental issue of the 1990s.

5. Change In Guns

Gun fluid nozzles, fluid needles and internal fluid passages, and cups must be able to resist corrosion. Stainless steel and Teflon® are the best materials because of their corrosion resistance. As waterbornes become more common, gun parts made of these materials will be more available.

6. Other Factors

There are some other factors to consider when applying waterborne materials:

Never reduce waterborne materials with tap water. Many manufacturers suggest that you not reduce their waterborne materials at all. Tap water often contains salts and minerals. The makeup of the materials found in water varies widely from region to region. It is nearly impossible to predict what effects these types of materials will have on the finished job, especially in the long term. Most manufacturers recommend the use of deionized water. This is water that has had salts and other materials removed. Deionized water should be available from your paint supplier.

Carefully follow the manufacturer's instructions for reducing. Painters often mix in more solvent or less solvent than the manufacturer recommends with little harmful effect. This is not the case when reducing waterbornes. The painter must be careful about the amount of water mixed into a waterborne material. Loss of control of the viscosity (thickness) of the material can occur even if the amounts are off just slightly. There is little margin for error in waterborne reducing ratios.

Do not mix waterborne materials with solvent-borne materials.

Combining two different paint systems that were never meant to be combined will give bad results. Make sure to spray water through the gun before spraying waterborne materials. This removes any solvents from the gun.

Spray waterborne materials wet. Dry coats allow water to bead up, causing imperfections in the finish.

WATERBORNE ADVANTAGES

The main reason these materials are so challenging to apply is because they are so new. Waterborne materials generally perform as well as solvent-borne, and offer several benefits that other materials do not.

First is the reduced VOC emission. There's also no bad odor, and the materials are not flammable. Even more importantly, these materials are "non-aggressive." They don't chemically react with the old finish on the vehicle, causing it to swell up or crack. Waterborne materials therefore work well as "barrier coats" between the old existing finish and the new finish.

WATERBORNE TOPCOATS

Waterborne topcoats are more difficult to make than waterborne undercoats. Basecoats are difficult to make as waterbornes because color and flake control are hard to achieve. Pigments and metallic flakes, the elements that give a topcoat color, have to be suspended in the basecoat.

The problem with waterborne clearcoats is the amount of material that must be used. Far too much material must be used to provide gloss and durability. Until this drawback is addressed, waterborne clears will not be released to the aftermarket. Single-stage waterborne topcoats for collision shops may not be available for several years. In the meantime, high-solids low-VOC paint technology is available now, and works well.

As paint manufacturers work on developing waterborne materials, I-CAR is working to keep you informed. Part 3 of the *I-CAR Finish Matching Course* covers the challenges the paint shop faces with new paint materials and equipment. **A**

Help For Handling Hazardous Waste

The solution to the hazardous waste handling puzzle is getting easier, and maybe more affordable, for collision repair shops. In the U.S., many states are developing programs to hold workshops and seminars on the subject. Federal grants are now available to help pay for handling hazardous waste. For example in EPA Region 10, which includes Washington, Oregon, Idaho, and Alaska, there's a grant project that conducts waste audits and information sessions throughout the region. Depending upon your state, there could be financial help for the purchase of hazardous waste controlling equipment, such as solvent recyclers and spray gun cleaners (see *Figure 1*).

Besides environmental damage, perhaps the biggest problem in dealing with hazardous waste is disposing of it properly. The question is not whether a collision shop has any hazardous waste. The question is how much hazardous waste the shop generates, and how it disposes of this waste. Controlling hazardous waste involves the following items:

- identifying the waste
- storing it according to the rules
- finding a certified hauler to dispose of the material
- understanding the local laws that apply to these wastes

WHAT MATERIALS ARE HAZARDOUS?

Waste materials are considered hazardous if they can cause injury or death, or can damage the land, air, or water. A hazardous waste may or may not be listed. However, if it is not listed in the rules, there are several tests to show if the waste is hazardous. Material used in the shop is generally classified as hazardous if it:

- is ignitable.
- is corrosive.
- is reactive.
- contains heavy metals.

Ignitable wastes are paint thinners and other solvents. **Corrosive** wastes include cleaning fluid, battery acid, and rust removers. **Reactive** wastes are unstable

Continued—Page 10

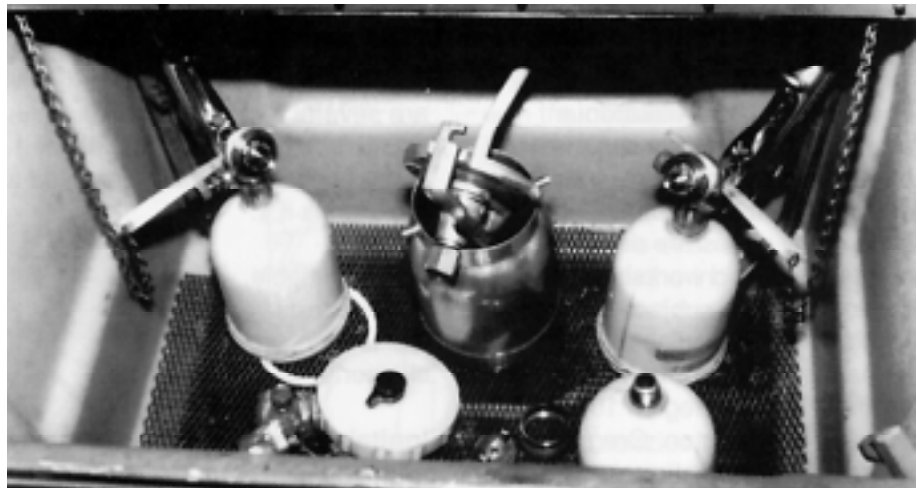

Figure 1—Spray gun cleaners are one type of equipment that could qualify for hazardous waste loans.

materials, such as bleaches, which undergo a rapid or violent chemical reaction when they come in contact with another substance. Wastes which contain heavy metals such as lead or mercury may leach into, and harm, the ground water. These wastes are found in used motor oil and some paint materials.

WHO DETERMINES IF A WASTE IS HAZARDOUS?

It is up to the person who uses the product to determine whether or not the waste from the product is hazardous. When in doubt, read the label. What's contained in most coating materials is on the label because of OSHA right to know rules. Many vehicle coatings contain **toluene** and **methyl ethyl ketones**. Both of them are listed as hazardous materials. The EPA provides a list of hazardous wastes typically produced in the collision shop.

Anytime there is a surplus of these wastes, or the material has long passed its shelf life and is no longer usable, it may be a hazardous waste (see Figure 2). If the cans are not properly stored or marked, they could cause problems for the shop. The local official may see them as hazardous waste.



Figure 2—Paint materials kept on the shelf past their useful life may be classified as hazardous waste. If the packages are not clearly marked, these materials could become the subject of a fine.

Shops fall into three EPA categories depending on how much hazardous waste is generated per month.

Category 1: no more than 220 pounds (100 kilograms) or 25 gallons (95 liters)

Category 2: 220–2,200 pounds (100–1000 kilograms) or 25–300 gallons (95–1100 liters)

Category 3: more than 2,200 pounds (1000 kilograms) or 300 gallons (1100 liters)

Most collision shops fall into the second category. These are U.S. Federal guidelines and don't always apply to each state or county. For instance, Pennsylvania only has two categories of hazardous waste generators. (The first two EPA categories are combined.)

STORING HAZARDOUS WASTES

Here are some typical state laws for storing hazardous waste on the shop site.

- Only one container per waste type is allowed.
- The storage site must be near the site of waste origin.
- The container must be securely closed.
- The type of waste and date the container is filled must be clearly marked on the container.
- The container must be moved to a disposal site within three days of when the container was filled.

Record-keeping is how the EPA determines what a collision shop does with hazardous waste. The record shows how much hazardous waste is being taken from the site. All shops need to keep the records, and list an EPA number on the record form. Shops that do not already have an EPA number, should get form "8700-12" from the regional EPA office and fill it out immediately.

FINDING A CERTIFIED HAULER

Shop owners can't haul the hazardous waste themselves. They need the services of an EPA-certified hauler. The hauler must have an EPA number. Contact the regional EPA office for a list of all haulers with EPA numbers.

Shops could face stiff fines for not following the law. For example, in New Jersey, the fine for failure of the collision shop to prepare an order before transporting hazardous waste off the site is \$10,000. It will cost \$25,000 if the waste is shipped to an unauthorized site. It's important to handle the paperwork correctly.

Dumping the waste down the sewer drain is no answer. In Colorado, there is a maximum fine of \$35,000 per day for illegally dumping hazardous waste down the sewer if it causes the local waste water treatment plant to

shut down. Fines depend on the size of the violation and the length of time it has occurred. Other states have similar fines.

An EPA publication, called *Understanding the Small Quantity Generator Hazardous Waste Rules: A Handbook for Small Business*, helps explain what hazardous waste laws mean to collision repair shops. This 1986 publication has all of the EPA guidelines for hazardous waste disposal. It also sets the guidelines for state laws. Some states have chosen to adopt these rules without rewording. Other states have set tougher standards

because they consider their problem with hazardous waste disposal greater than the national average.

The cost of following the law can be very high when the training and equipment investments are added up. State sponsored programs help offset the training cost. There may also be financial help from the Small Business Administration (SBA). If a collision repair shop meets the qualifications of a small business as outlined by the SBA, it could be eligible for the Pollution Control Loan (PCL) program. Under this program, the SBA would guarantee loans to small busi-

nesses that meet their credit requirements. The loans are made by private lenders and are guaranteed by the SBA. These loans are used to buy hazardous waste control equipment. Contact the Small Business Ombudsman at (800) 368-5888 for more information on the PCL program.

Hazardous waste doesn't have to be a costly burden for the shop or the environment. By paying attention to these rules, and seeking help that is now available, pollution problems and stiff penalties can be avoided. **A**